



बैंक नोट पेपर मिल इण्डिया प्रा. लिमिटेड

BANK NOTE PAPER MILL INDIA PVT LIMITED

JV of SPMCIL - A Govt. of India Enterprises & BRBNMPL - A Subsidiary of RBI

email : scmcommon@bnpmindia.com, Ph: 0821 2401 178

Limited Tender Enquiry No: BNPM/LTE/Safety Shear Bolt/366/2018-19

Enquiry issuing Date: 28.07.2018

Closing date: 3.08.2018 @ 1000 Hrs

1. Scope of work:

Supply of **Safety Shear Bolt**

2. Terms & Conditions:

S. No.	Particulars	Quantity
1.	Payment Terms	100% on receipt and acceptance of goods by the consignee at destination and on production of all required documents by the supplier. <u>Warranty certificate (if applicable) and NEFT/RTGS details shall be furnished along with invoice.</u>
2.	Price	Price should be inclusive of taxes,
3.	Freight	Shall be included in quoted price
4.	Packing & Forwarding	Shall be included in quoted price
5.	Delivery Terms	DAP, Bank Note Paper Mill India Private Limited, Mysore
6.	Warranty Period
7.	Warranty Certificate	Applicable / Not Applicable
8.	Delivery Period
9.	Material to be delivered at	Engineering Stores Bank Note Paper Mill India Private Limited Note Mudran Nagar Mysore 570 003
10.	Contact person in Engineering Stores	Mr. N. Saideep 0821-2401178 Email: Scmcommon@bnpmindia.com



Price Bid Format:

S. No.	Description	Qty.	UOM	Unit rate	Freight, P&F Charges	GST@	Unit rate including GST & Freight, P&F Charges	Grand total inclusive of GST and Freight, P&F Charges (DAP, BNPM, Mysore)
1.	Safety Shear bolt-GLT	30	Nos					
2.	Safety Shear Nut-GLT	30	Nos					
3.	Locking Pin for Safety Shear Bolt	10	Nos					
Total price inclusive of all tax, freight , P&F charges								

Note:

1. For nuts & bolts attached drawings
2. L1 bidder shall supply five pieces of each of safety shear bolt and nut. If found suitable on machine, then balance quantity may be supplied.

We hereby confirm that

1. We accept all terms & conditions mentioned in the enquiry.
2. Price quoted is inclusive of all taxes, P&F, freight etc. on DAP, BNPM, Mysore basis.
3. HSN Code:

Signature of bidder:.....

Name of the Firm:.....

Seal of the firm:

GST No:



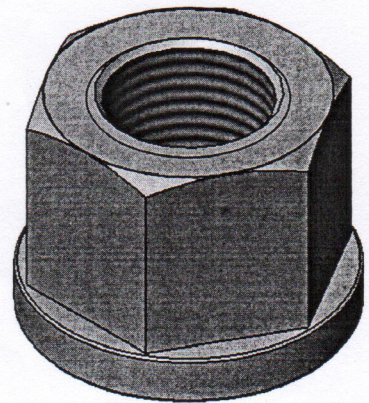
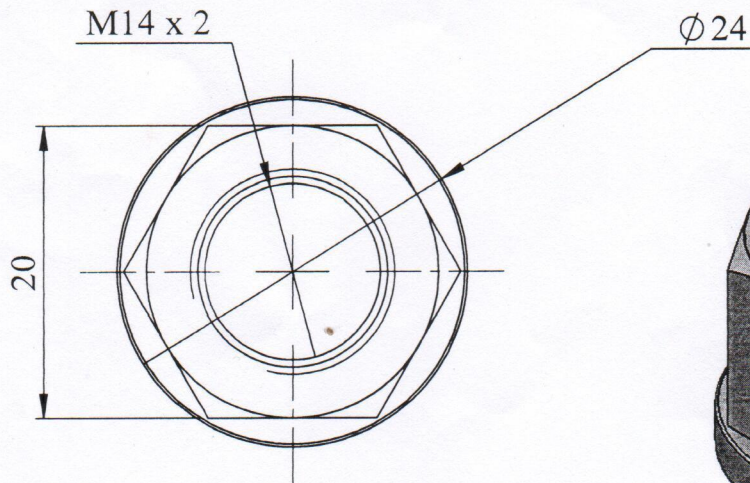
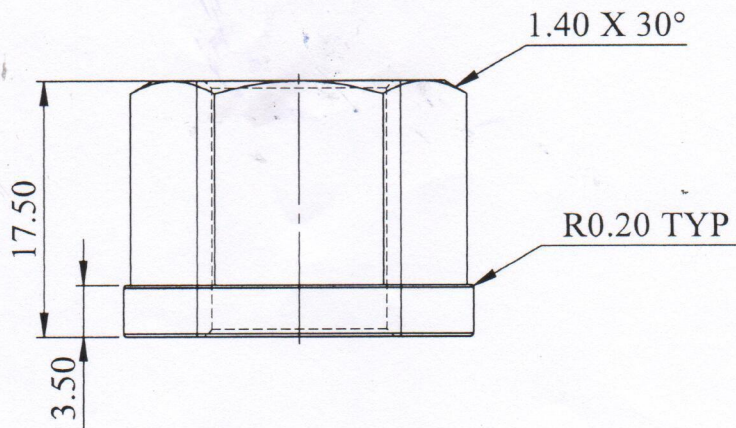

All dimensions are in mm
 Note : Unspecified tolerance is +/- 0.1
 General tolerance is +/- 0.15

UNLESS OTHERWISE SPECIFIED: DIMENSIONS ARE IN MILLIMETERS SURFACE FINISH: TOLERANCES: LINEAR: ANGULAR:		FINISH:		DEBUR AND BREAK SHARP EDGES		DO NOT SCALE DRAWING		REVISION	
						DWG NO.			
						TITLE:			
						SAFETY NUT			
						MATERIAL: Structural steel- IS-2062			
						A4			
						SCALE: 2:1		SHEET 1 OF 1	

DRAWN: *[Signature]*
 CHK'D: *[Signature]*
 APPV'D: *[Signature]*
 MFG: *[Signature]*
 Q.A: *[Signature]*
 K.L. PRIKASH
 Dy. General Manager
 Govt. Tool Room & Training Centre
 Plot No. 93 & 94, Eagle Gate Ind. Estate
 K.P.S. Road, Mysore-570011

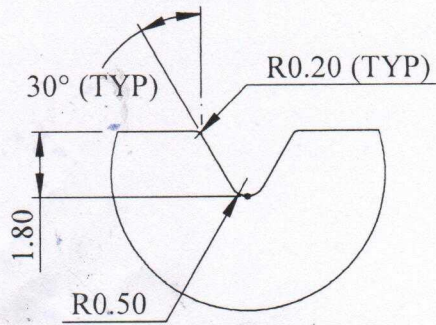

DETAIL-A
SCALE 5 : 1

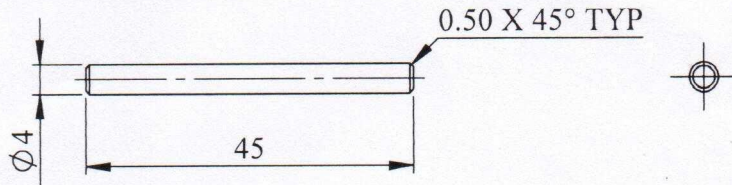
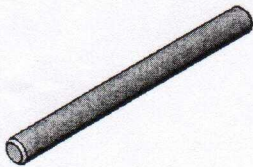
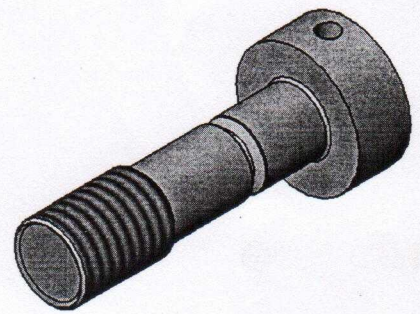
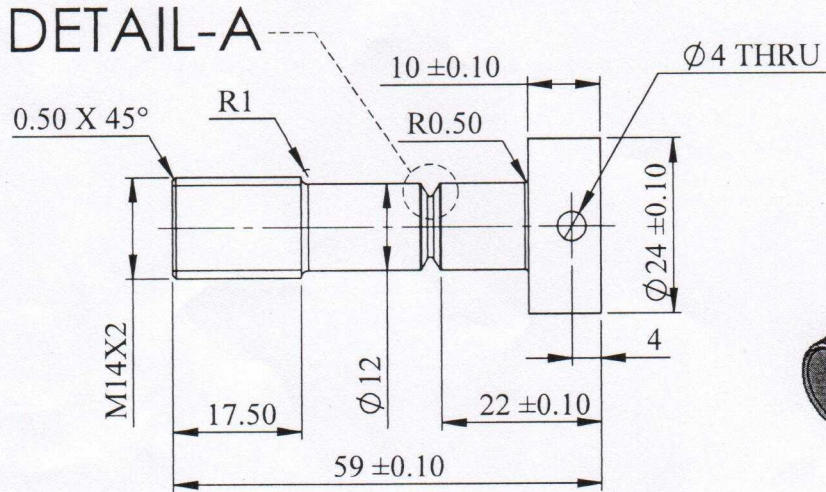

ALL DIMENSIONS ARE IN MM

Note: Unspecified tolerance is +/- 0.1
General tolerance is +/- 0.15

UNLESS OTHERWISE SPECIFIED: DIMENSIONS ARE IN MILLIMETERS SURFACE FINISH: TOLERANCES: LINEAR: ANGULAR:		FINISH:	DEBUR AND BREAK SHARP EDGES	DO NOT SCALE DRAWING	REVISION
DRAWN	NAME	SIGNATURE	DATE	TITLE: SAFETY BOLT & PIN	
CHK'D			28/13/18	DWG NO. A4	
APPV'D					
MFG					
Q.A				MATERIAL: Structural Steel IS-2062	SCALE:1:1 SHEET 1 OF 1

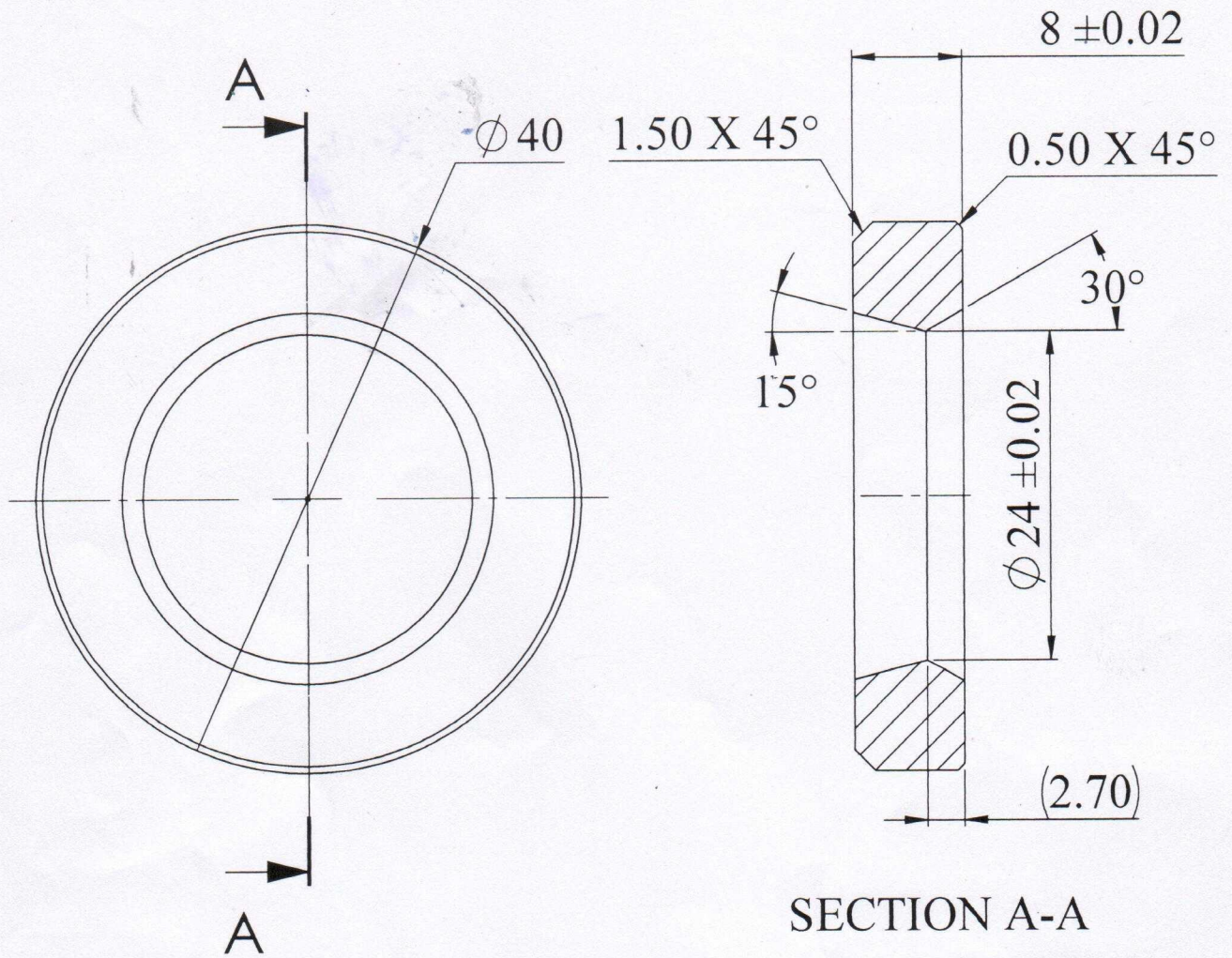

SECTION A-A

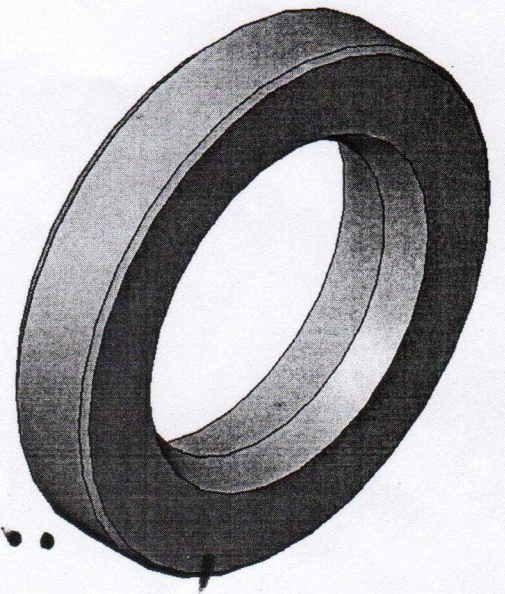

Note : All dimensions are in mm
 Unspecified tolerance is +/- 0.1
 General tolerance +/-0.15

UNLESS OTHERWISE SPECIFIED: DIMENSIONS ARE IN MILLIMETERS SURFACE FINISH TOLERANCES: LINEAR ANGULAR:		FINISH:	DEBUR AND BREAK SHARP EDGES	DO NOT SCALE DRAWING	REVISION
NAME	SIGNATURE	DATE	TITLE: <h1>SAFETY RING</h1>		
DRAWN	<i>[Signature]</i>	<i>[Date]</i>			
CHK'D	<i>[Signature]</i>	<i>[Date]</i>			
APPV'D	<i>[Signature]</i>				
MFG	<i>[Signature]</i>				
QA	<i>[Signature]</i>		MATERIAL: Carbon Steel - 45C8	A4	
K.R.S. Road, Mysore-578016 Dy. Genl. Mgr. & In-charge Genl. Tool Room & Training C.			SCALE: 2:1	SHEET 1 OF 1	